

# Application GN11

## Natural Gas (SGERG / AGA-8 Gross) Flow Computer

for Frequency Flowmeter

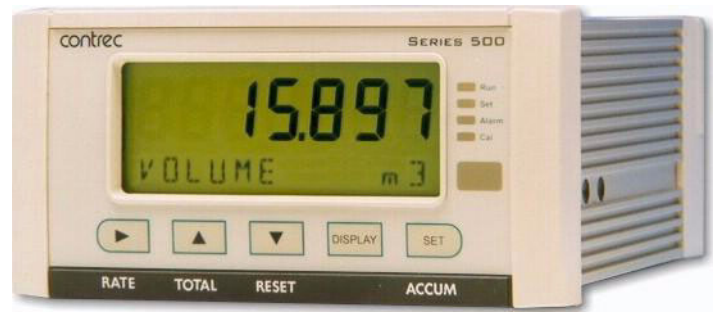

### Features

- Uses SGERG (AGA-8 Gross Method) Natural Gas compressibility calculations
- For Natural and Coke-Oven Gases
- Allows quadrature flow input for ISO 6551 level B pulse security
- Allows for non-linear correction
- Selection of second language and user tags
- RTC logging with over 1000 entries
- Infra-red communications port on front panel
- Pulse width and scaling of pulse output
- 4-20mA retransmission
- Selectable protocols on serial ports including Modbus RTU and Printer output
- Front panel adjustment of 8-24V DC output voltage
- Backlit display
- LCD backup



### Overview

The 515 GN11 application measures the volume, mass and gross heat content of natural gas. The instrument uses a frequency volume flow input and analog temperature and pressure sensor inputs.

The instrument is compatible with a wide range of flowmeter frequency outputs. Millivolt signals, reed switches, Namur proximity switches or pulse trains can be selected via its smart front-panel programming.

The SGERG calculation (AGA-8 Gross Characterization Method) is used to obtain accurate values of density and compressibility factors for the flow calculations.

### Calculations

The gas density and compressibility factor calculations are based on the SGERG (AGA-8 Gross) equations. The calculations are valid for the region:

$$-8.0^{\circ}\text{C} < t < 62.0^{\circ}\text{C} \quad P < 12\text{MPa}$$

$$17^{\circ}\text{F} < t < 143.0^{\circ}\text{F} \quad P < 1740\text{psia}$$

### Formulas

$$M_{flow} = Volume_{flow} \cdot \rho_{flow}$$

$$Corrected\ flow = M_{flow} / \rho_{ref}$$

$$Heat\ flow = M_{flow} \cdot H_m$$

where:

$$M_{flow} = \text{mass flow}$$

$$\rho_{flow} = \text{density at flow conditions}$$

$$\rho_{ref} = \text{density at reference conditions}$$

$$H_m = \text{mass gross heating value}$$

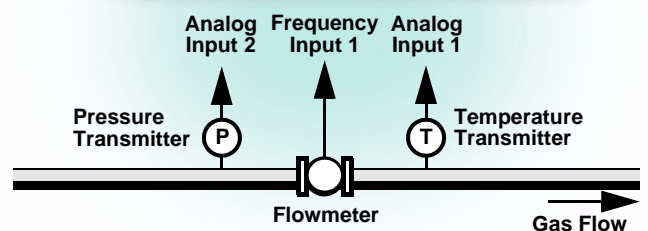
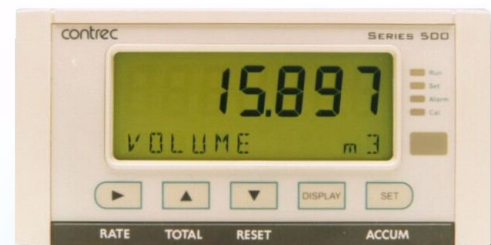

## Displayed Information

The front panel display shows the current values of the input variables and the results of the calculations. A list of the variables for this application and their type (total or rate) is shown at the end of this document.

The instrument can be supplied with a real-time clock for data logging of over 1000 entries of the variables as displayed on the main menu.

## Communications

There are three communication ports available as follows:

- RS-232 port (standard)
- RS-485 port (advanced option)
- Infra-red port (on front panel)

The ports are available for remote data reading, printouts and for initial application loading of the instrument.

## Isolated Outputs

The opto-isolated outputs can re-transmit any main menu variable. The type of output is determined by the nature of the assigned variable. Totals are output as pulses and rates are output as 4-20mA signals. One output is standard, a second output is available as an option.

## Relay Outputs

The relay alarms can be assigned to any of the main menu variables of a rate type. The alarms can be fully configured including hysteresis. Two relays are standard with an additional two available in the advanced option.

## Software Configuration

The instrument can be further tailored to suit specific application needs including units of measurement, custom tags, second language or access levels. A distributor can configure these requirements before delivery.

Instrument parameters including units of measurement can be programmed in the field, according to the user access levels assigned to parameters by the distributor.

All set-up parameters, totals and logged data are stored in non-volatile memory with at least 30 years retention.

## Temperature and Pressure Input Types

Temperature sensor input can be either PT100, PT500, 4-20mA, 0-5V or 1-5V signals. Pressure sensor input can be either 4-20mA, 0-5V or 1-5V signals.

## Terminal Designations

Terminal Label	Designation	Comment
1	FINP 1+	Frequency Input 1+
2	FINP 2+	Frequency Input 2+
3	SG	Signal ground
5	EXC V 2+	Excitation Term 2+
		For AINP1 RTD input
7	AINP1 +	Analog input ch 1 (+)
8	AINP1 -	Analog input ch 1 (-)
		Temperature input
9	AINP2 +	Analog input ch 2 (+)
10	AINP2 -	Analog input ch 2 (-)
		Pressure input
15	Vo +	8-24 volts DC output
16	G -	DC Ground
17	Vi +	DC power input
18	SH E	Shield terminal
		Overload protected
19	RS485 +	RS485 (+)
20	RS485 -	RS485 (-)
21	G	RS485 ground
		Advanced option
22	LOGIC INPUTS 1+	Switch 1
23	LOGIC INPUTS 2+	Switch 2
24	LOGIC INPUTS 3+	Switch 3
25	LOGIC INPUTS 4+	Switch 4
26	LOGIC INPUTS C-	Signal ground
27	OUT 1 +	Output ch 1 (+)
28	OUT 1 -	Output ch 1 (-)
29	OUT 2 +	Output ch 2 (+)
30	OUT 2 -	Output ch 2 (-)
		Advanced option
31	RELAYS RC	Relay common
32	RELAYS R1	Relay 1
33	RELAYS R2	Relay 2
34	RELAYS R3	Relay 3
35	RELAYS R4	Relay 4
		Advanced option
E	AC MAINS E	Mains ground
N	AC MAINS N	Mains neutral
A	AC MAINS A	Mains active
		AC power in 95-135V or 190-260V
RS232 port		9-pin serial port

## Dimension Drawings

### Part Number

515-XXXXXX-GN11  
see **Product Codes** to select required features

Default Application software:  
515-GN11-000000

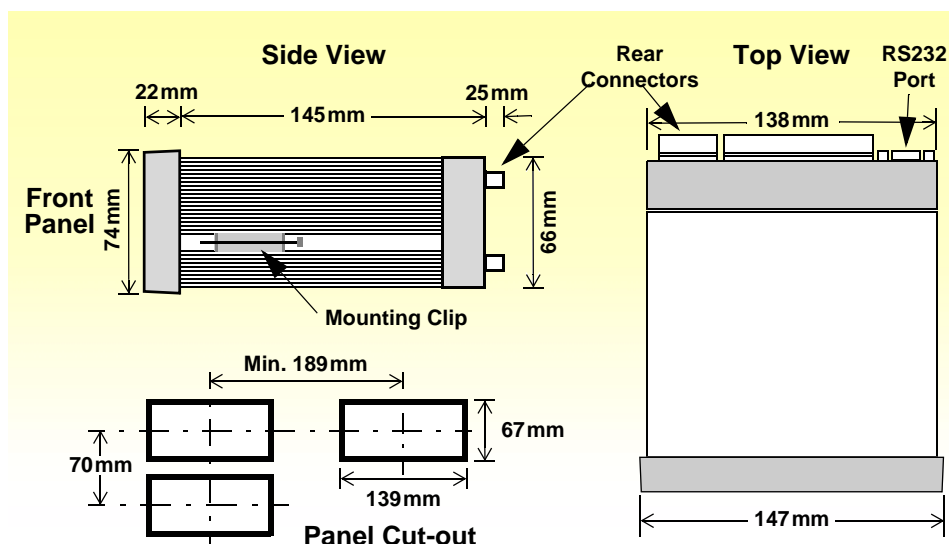

# Specifications

## General

### Operating Environment

<b>Temperature</b>	-20°C to +60°C (conformal coating) +5°C to +40°C (no coating)
<b>Humidity</b>	0 to 95% non condensing (conformal coating) 5% to 85% non condensing (no coating)
<b>Power Supply</b>	95...135 V AC or 190...260 V AC or 12...28 V DC
<b>Consumption</b>	Typically 6W
<b>Protection</b>	Sealed to IP65 (Nema 4X) when panel mounted
<b>Dimensions</b>	147mm (5.8") width 74mm (2.9") height 167mm (6.6") depth

### Display

<b>Type</b>	Backlit LCD with 7-digit numeric display and 11-character alphanumeric display
<b>Digits</b>	15.5mm (0.6") high
<b>Characters</b>	6mm (0.24") high
<b>LCD Backup</b>	Last data visible for 15min after power down
<b>Update Rate</b>	0.3 second

### Non-volatile Memory

<b>Retention</b>	> 30 years
<b>Data Stored</b>	Setup, Totals and Logs

### Approvals

<b>Interference</b>	CE compliance
<b>Enclosure</b>	ATEX, FM, CSA and SAA approved enclosures available for hazardous areas

### Real Time Clock (Optional)

<b>Battery Type</b>	3 volts Lithium button cell (CR2032)
<b>Battery Life</b>	5 years (typical)

## Inputs

### Frequency Input (General)

<b>Range</b>	0 to 10kHz
<b>Overvoltage</b>	30V maximum
<b>Update Time</b>	0.3 sec
<b>Cutoff frequency</b>	Programmable
<b>Configuration</b>	Pulse, coil or NPS input
<b>Non-linearity</b>	Up to 10 correction points

### Pulse

<b>Signal Type</b>	CMOS, TTL, open collector, reed switch
<b>Threshold</b>	1.3 volts

### Coil

<b>Signal Type</b>	Turbine and sine wave
<b>Sensitivity</b>	15mV p-p minimum

### NPS

<b>Signal Type</b>	NPS sensor to Namur standard
--------------------	------------------------------

### Analog Input (General)

<b>Overcurrent</b>	100mA absolute maximum rating
<b>Update Time</b>	< 1.0 sec
<b>Configuration</b>	RTD, 4-20mA, 0-5V and 1-5V input
<b>Non-linearity</b>	Up to 20 correction points (flow inputs)

### RTD Input

<b>Sensor Type</b>	PT100 & PT500 to IEC 751
<b>Connection</b>	Four Wire
<b>Range</b>	-100°C to 300°C
<b>Accuracy</b>	0.1°C typical

### 4-20 mA Input

<b>Impedance</b>	100ohms (to common signal ground)
<b>Accuracy</b>	0.05% full scale (20°C) 0.1% (full temperature range, typical)

### 0-5 or 1-5 Volts Input

<b>Impedance</b>	10Mohms (to common signal ground)
<b>Accuracy</b>	0.05% full scale (20°C) 0.1% (full temperature range, typical)

### Logic Inputs

<b>Signal Type</b>	CMOS, TTL, open collector, reed switch
<b>Overvoltage</b>	30V maximum

## Outputs

### Relay Output

<b>No. of Outputs</b>	2 relays plus 2 optional relays
<b>Voltage</b>	250 volts AC, 30 volts DC maximum (solid state relays use AC only)
<b>Current</b>	3A maximum

### Communication Ports

<b>Ports</b>	RS-232 port RS-485 port (optional) Infra-red port
<b>Baud Rate</b>	2400 to 19200 baud
<b>Parity</b>	Odd, even or none
<b>Stop Bits</b>	1 or 2
<b>Protocols</b>	ASCII, Modbus RTU, Printer

### Transducer Supply

<b>Voltage</b>	8 to 24 volts DC, programmable
<b>Current</b>	70mA @ 24V, 120mA @ 12V maximum
<b>Protection</b>	Power limited output

### Isolated Output

<b>No. of Outputs</b>	1 configurable output (plus 1 optional)
<b>Configuration</b>	Pulse/Digital or 4-20mA output

### Pulse/Digital Output

<b>Signal Type</b>	Open collector
<b>Switching</b>	200mA, 30 volts DC maximum
<b>Saturation</b>	0.8 volts maximum
<b>Pulse Width</b>	Programmable: 10, 20, 50, 100, 200 or 500ms

### 4-20 mA Output

<b>Supply</b>	9 to 30 volts DC external
<b>Resolution</b>	0.05% full scale
<b>Accuracy</b>	0.05% full scale (20°C) 0.1% (full temperature range, typical)

*Important: Specifications are subject to change without notice.*

# Ordering Information

## Product Codes

Model	Supplementary Code						Description
515	- GN11						
Enclosure	1						Panel mount enclosure
	2						Field mount enclosure (not yet available)
	3/5						Explosion proof Ex410 with metric glands (5 specifies heater version)
	4/6						Explosion proof Ex410 with NPT glands (6 specifies heater version)
Output Options	0						4 logic inputs, 1 isolated output, 2 relays (only relay type 1 is available), RS232 (DB9) communication port
	1						4 logic inputs, 2 isolated outputs, 4 relays, real-time clock data logging, RS232 (DB9) and RS485 communication ports
	2/3						4 logic inputs, 2 isolated outputs, 4 relays, real-time clock data logging, RS232 (DB9) and Ethernet/RF communication ports (not yet available)
Relay Type	1						Electromechanical relays only
	2						2 electromechanical and 2 solid state relays
	3						Solid state relays only (not yet available)
Power Supply	E						For 220/240 VAC
	A						For 110/120 VAC
	D						For DC power only 12-28 VDC
Display Panel Option		F					Fully optioned (with backlight, LCD backup and Infra-Red comms port)
PCB Protection			C				<b>Conformal coating</b> - required for maximum environmental operating range. Recommended to avoid damage from moisture and corrosion.
			N				<b>None</b> - suitable for IEC standard 654-1 Climatic Conditions up to Class B2 (Heated and/or cooled enclosed locations)
Application Pack Number			GN11				Defines the application software to be loaded into the instrument

Example full product part number is 515.111EFC-GN11 (This is the number used for placing orders).

## Main Menu Variables

Main Menu Variables	Default Units	Preferred Units	Variable Type
Volume	m <sup>3</sup>		Total
Volume Flowrate	m <sup>3</sup> /min		Rate
Corrected Volume	m <sup>3</sup>		Total
Corrected Flowrate	m <sup>3</sup> /min		Rate
Heat	GJ		Total
Heat Flowrate	GJ/h		Rate
Mass	kg		Total
Mass Flowrate	kg/min		Rate
Temperature	Deg C		Rate
Pressure	MPa		Rate
Compressibility Factor	---	---	Rate

Please specify the preferred units of measurement.



500 Series in Ex410 Enclosure

[www.contrec.com.au](http://www.contrec.com.au)

### Contrec Pty Ltd

22 Hall Street Hawthorn East  
Victoria 3123 AUSTRALIA  
Tel: +61 3 9804 4200 Fax: +61 3 9822 8329  
Email: sales@contrec.com.au

### Contrec Europe Limited

PO Box 436 Sowerby Bridge,  
West Yorkshire HX6 3YA, UK  
Tel: +44 1422 829 940 Fax +44 1422 829 941  
Email: sales@contrec.co.uk

### Contrec - USA, LLC

916 Belcher Drive, Pelham AL 35124 USA  
Tel: (205) 685 3000 Fax: (205) 685 3001  
Email: contrec@contrec-usa.com