

Application BF01

Dual Stage Batch/Flow Controller

for Volumetric Frequency
Flowmeters

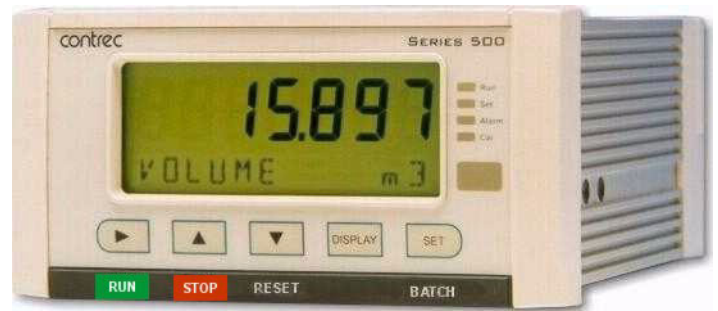

Features

- Tailored for volumetric frequency flow input
- Single or Dual stage control
- Preset or manual On-Off modes
- Easy access to batch and flow rate presets
- No-flow, leakage and overflow error detection
- Remote RUN/STOP/RESET
- Allows for permissive with prompt
- Uses PI Loop Control
- Allows for non-linear correction
- Storage of 1000 transactions with time and date stamp
- Selection of second language and user tags
- Selectable protocols on serial ports including Modbus RTU and Printer output
- Backlit display with LCD backup



Overview

The 515 BF01 application is a batching flow controller for delivery of preset quantities at preset flowrates using a volumetric frequency input. Batch control can operate in preset or on-off modes, while flow control can be set to local (manual) or PI loop mode.

This application provides the operator with clear local readout including flowrate deviation and can be controlled via communications in more automated systems. There is quick access to commonly used preset values directly from the front panel if access has been authorized.

The PI control of the process flow is via a 4-20mA proportional valve or pump controller. It has integral wind-up protection, a deadband, output hold and ramp time that can be programmed to reduce wear on valves and actuators and provide for bumpless operation.

Calculations

The total and flowrate are derived from accurately measured frequency and the number of received pulses.

$$volume = pulses / k-factor$$

$$volume\ flow = frequency / k-factor$$

Automatic overrun compensation calculates the new valve closure point to ensure correct delivery by averaging the overrun amount from the last three complete batches.

The overrun compensation value is valid for a new preset value provided the stored overrun is less than 20% of the new preset.

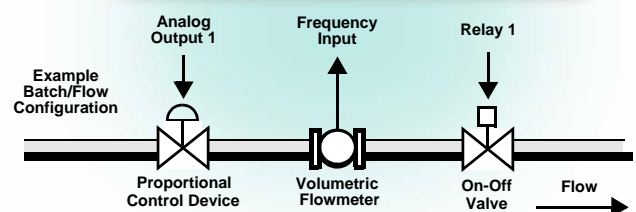

Displayed Information

The front panel display shows the current values of the input variables and the results of the calculations. A list of the variables for this application and their type (total or rate) is shown at the end of this document.

The instrument can be supplied with a real-time clock for storage of up to 1000 transactions with time and date stamps.

Communications

There are three communication ports available as follows:

- RS-232 port (standard)
- RS-485 port (advanced option)
- Infra-red port (on front panel)

The ports are available for remote data reading, printouts and for initial application loading of the instrument.

Isolated Outputs

The opto-isolated outputs can retransmit any main menu variable. The type of output is determined by the nature of the assigned variable. Totals are output as pulses and rates are output as 4-20mA signals. One output is standard, a second output is available as an option.

Relay Outputs

The relay outputs 1 and 2 are used to control the flow of product for each delivery. These contacts are normally open and can be used to drive external relays, valves, pump circuits etc. The advanced option provides another two relays that can be used as fully programmable alarms for any rate type variable.

Software Configuration

The instrument can be further tailored to suit specific application needs including units of measurement, custom tags, second language or access levels. A distributor can configure these requirements before delivery.

Instrument parameters including units of measurement can be programmed in the field, according to the user access levels assigned to parameters by the distributor.

All set-up parameters, totals and logged data are stored in non-volatile memory with at least 30 years retention.

Terminal Designations

Terminal Label	Designation	Comment
1 FINP	1+	Frequency Input 1+
3 SG	-	Signal ground
15 Vo	+	8-24 volts DC output
16 G	-	DC Ground
17 Vi	+	DC power input
18 SH	E	Shield terminal
19	+	RS485 (+)
20 RS485	-	RS485 (-)
21	G	RS485 ground
22	1+	Switch 1
23	2+	Switch 2
24 LOGIC INPUTS	3+	Switch 3
25	4+	Switch 4
26	C-	Signal ground
27	+	Output ch 1 (+)
28 OUT 1	-	Output ch 1 (-)
29	+	Output ch 2 (+)
30 OUT 2	-	Output ch 2 (-)
31	RC	Relay common
32	R1	Relay 1
33 RELAYS	R2	Relay 2
34	R3	Relay 3
35	R4	Relay 4
E	E	Mains ground
N	N	Mains neutral
A	A	Mains active
RS232 port		9-pin serial port

Dimension Drawings

Part Number

515-XXXXXX-BF01
see **Product Codes** to select required features

Default Application software:
515-BF01-000000

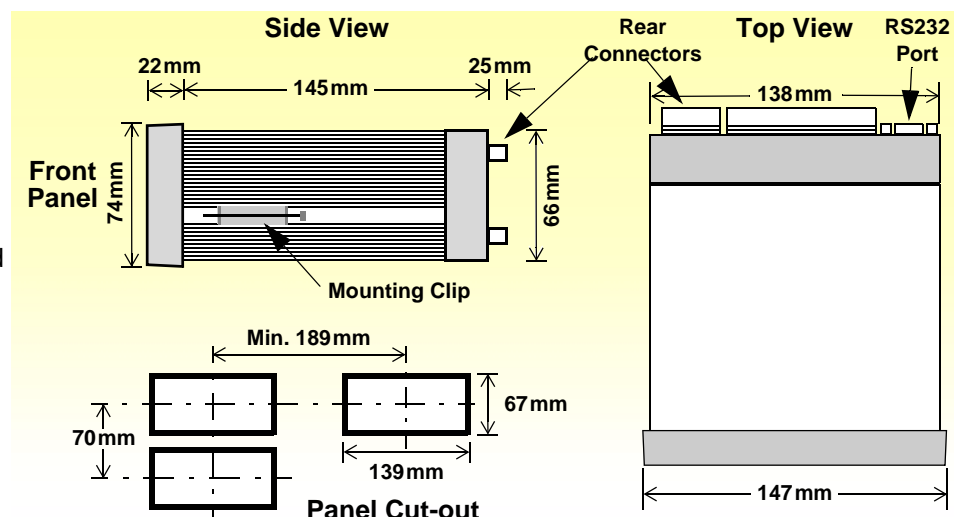

Specifications

General

Operating Environment

Temperature	-20°C to +60°C (conformal coating) +5°C to +40°C (no coating)
Humidity	0 to 95% non condensing (conformal coating) 5% to 85% non condensing (no coating)
Power Supply	95...135 V AC or 190...260 V AC or 12...28 V DC
Consumption	Typically 6W
Protection	Sealed to IP65 (Nema 4X) when panel mounted
Dimensions	147mm (5.8") width 74mm (2.9") height 167mm (6.6") depth

Display

Type	Backlit LCD with 7-digit numeric display and 11-character alphanumeric display
Digits	15.5mm (0.6") high
Characters	6mm (0.24") high
LCD Backup	Last data visible for 15min after power down
Update Rate	0.3 second

Non-volatile Memory

Retention	> 30 years
Data Stored	Setup, Totals and Logs

Approvals

Interference	CE compliance
Enclosure	ATEX, FM, CSA and SAA approved enclosures available for hazardous areas

Real Time Clock (Optional)

Battery Type	3 volts Lithium button cell (CR2032)
Battery Life	5 years (typical)

Inputs

Frequency Input (General)

Range	0 to 10kHz
Overvoltage	30V maximum
Update Time	0.3 sec
Cutoff frequency	Programmable
Configuration	Pulse, coil or NPS input
Non-linearity	Up to 10 correction points

Pulse

Signal Type	CMOS, TTL, open collector, reed switch
Threshold	1.3 volts

Coil

Signal Type	Turbine and sine wave
Sensitivity	15mV p-p minimum

NPS

Signal Type	NPS sensor to Namur standard
--------------------	------------------------------

Logic Inputs

Signal Type	CMOS, TTL, open collector, reed switch
Overvoltage	30V maximum

Outputs

Relay Output

No. of Outputs	2 relays plus 2 optional relays
Voltage	250 volts AC, 30 volts DC maximum (solid state relays use AC only)
Current	3A maximum

Communication Ports

Ports	RS-232 port RS-485 port (optional) Infra-red port
Baud Rate	2400 to 19200 baud
Parity	Odd, even or none
Stop Bits	1 or 2
Protocols	ASCII, Modbus RTU, Printer

Transducer Supply

Voltage	8 to 24 volts DC, programmable
Current	70mA @ 24V, 120mA @ 12V maximum
Protection	Power limited output

Isolated Output

No. of Outputs	1 configurable output (plus 1 optional)
Configuration	Pulse/Digital or 4-20mA output

Pulse/Digital Output

Signal Type	Open collector
Switching	200mA, 30 volts DC maximum
Saturation	0.8 volts maximum
Pulse Width	Programmable: 10, 20, 50, 100, 200 or 500ms

4-20 mA Output

Supply	9 to 30 volts DC external
Resolution	0.05% full scale
Accuracy	0.05% full scale (20°C) 0.1% (full temperature range, typical)

Important: Specifications are subject to change without notice.

Ordering Information

Product Codes

Model	Supplementary Code						Description
515	- BF01						
Enclosure	1						Panel mount enclosure
	2						Field mount enclosure (not yet available)
	3/5						Explosion proof Ex410 with metric glands (5 specifies heater version)
	4/6						Explosion proof Ex410 with NPT glands (6 specifies heater version)
Output Options	0						4 logic inputs, 1 isolated output, 2 relays (only relay type 1 is available), RS232 (DB9) communication port
	1						4 logic inputs, 2 isolated outputs, 4 relays, real-time clock data logging, RS232 (DB9) and RS485 communication ports
	2/3						4 logic inputs, 2 isolated outputs, 4 relays, real-time clock data logging, RS232 (DB9) and Ethernet/RF communication ports (not yet available)
Relay Type	1						Electromechanical relays only
	2						2 electromechanical and 2 solid state relays
	3						Solid state relays only (not yet available)
Power Supply	E						For 220/240 VAC
	A						For 110/120 VAC
	D						For DC power only 12-28 VDC
Display Panel Option	F						Fully optioned (with backlight, LCD backup and Infra-Red comms port)
PCB Protection	C						Conformal coating - required for maximum environmental operating range. Recommended to avoid damage from moisture and corrosion.
	N						None - suitable for IEC standard 654-1 Climatic Conditions up to Class B2 (Heated and/or cooled enclosed locations)
Application Pack Number	BF01						Defines the application software to be loaded into the instrument

Example full product part number is 515.111EFC-BF01 (This is the number used for placing orders).

Main Menu Variables

Main Menu Variables	Default Units	Preferred Units	Variable Type
Volume	Ltr		Total
Volume Flowrate	L/min		Rate
Control Output	%		Rate
Flowrate Deviation	%		Rate

Please specify the preferred units of measurement.



500 Series in Ex410 Enclosure

www.contrec.com.au

Contrec Pty Ltd

22 Hall Street Hawthorn East
Victoria 3123 AUSTRALIA
Tel: +61 3 9804 4200 Fax: +61 3 9822 8329
Email: sales@contrec.com.au

Contrec Europe Limited

PO Box 436 Sowerby Bridge,
West Yorkshire HX6 3YA, UK
Tel: +44 1422 829 940 Fax +44 1422 829 941
Email: sales@contrec.co.uk

Contrec - USA, LLC

916 Belcher Drive, Pelham AL 35124 USA
Tel: (205) 685 3000 Fax: (205) 685 3001
Email: contrec@contrec-usa.com