

# Steam to Condensate Computer

**Model 415C**

## Features

- Calculates Net Energy used in the system
- Displays mass flow, steam energy and condensate energy
- Accepts 4-20mA and frequency flow inputs
- Temperature and pressure compensation
- Operates from 14-28V dc or ac mains
- Simplified programming
- Data logging output



## Overview

In steam heating applications, where the condensate is returned without loss to the boiler, the Model 415C Steam to Condensate Computer provides a convenient method to measure the Net Energy used in the system.

A flowmeter in the steam line, together with temperature and pressure sensors, is used to calculate the mass flow and energy of the steam.

Providing the return line contains only condensate and is free of steam, it is possible to measure the return energy only by measuring the temperature of the condensate. In addition to displaying both the feed energy and return energy, the Net Energy used in the load is calculated and displayed.

The Model 415C relies on the system being loss free in which case the mass of steam in the feed line will equal the mass of condensate in the return line.

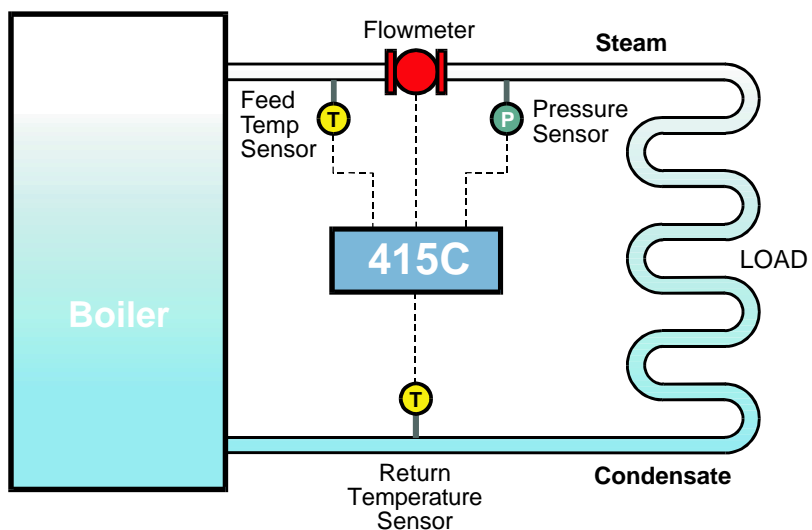

# Steam to Condensate Computer

## Model 415C

For applications where the steam is saturated, the system allows the use of either a temperature or pressure sensor, rather than requiring both sensors. Steam and condensate energy are calculated using the 1967 IFC Formulation (ASME) equations to determine the specific weight and enthalpies.

### Wide range of flowmeter inputs

Inputs from a wide range of flowmeters are accepted, including vortex, turbine, orifice plate, averaging pitot tubes, wedges and target flowmeters.

A scaled output, suitable for driving remote totalisers, is a standard feature, while options include an isolated 4-20mA re-transmission, high & low flow alarms and an RS232/422 output.

The pulse output, 4-20mA re-transmission and alarms will operate on the net energy.

### RS232/422 output enables data logger operation

The RS232/422 option will output all parameters displayed and has the unique ability to print flow rates and totals at programmable time intervals. This enables the 415C to function as a data logger when used in conjunction with a printer or other storage device.

Protocols are provided for standard roll and column printers as well as for computer interfaces. A real time clock provides time and date. The totals can be programmed to reset via the front panel, after each print or at 24:00 hours.

### Easy to read backlit alpha-numeric display

The Model 415C is fully programmable and all operating parameters are entered via the front panel keypad. The backlit alphanumeric display simplifies programming and provides a clear indication of all parameters, as well as engineering units.

### Flowmeter Inputs

The 415C accepts most flowmeter inputs including:

- Frequency producing flowmeters such as vortex, turbine or positive displacement.
- Volumetric flowmeters with 4-20mA outputs such as vortex or turbines with a frequency to current converter on the output.
- Differential Pressure devices such as orifice plates, averaging pitot tubes, wedges, cones, elbows or target flowmeters, where a square law relationship applies.
- Linear Differential Pressure devices where the 4-20mA output is directly proportional to the flow rate.
- Non-Linear Differential Pressure devices such as laminar flow tubes or VA meters. A 20 point correction curve can be programmed to compensate for any non-linearities in the flowmeter.

### Parameters Displayed

The DISPLAY key can be used to display the following:

- Net Energy (Rate and Total) (MJ or Btu x 1000)
- Mass (kg or lbs) (Rate and Total)
- Steam Energy (Rate and Total) (MJ or Btu x 1000)
- Condensate Energy (Rate and Total) (MJ or Btu x 1000)
- Steam Temperature (°C or °F)
- Steam Pressure (kPa or psi)
- Specific Weight and Enthalpy of Steam
- Specific Enthalpy and Temperature of Condensate

Totals are displayed with a maximum of 8 digits, including decimals. For example, if two decimals are programmed, the maximum total is 999,999.99, after which the totals roll over to zero and continue counting.

For large flow rates, totals can be integrated in tonnes and GJ (klbs and MBtu).

## General

<b>Display</b>	2 line x 20 character (5.5mm high) alphanumeric backlit LCD.
<b>Keypad</b>	Sealed membrane keypad with four keys.
<b>Transducer Supply</b>	8-24V dc field adjustable, 65mA max.
<b>Power Requirements</b>	
dc Supply:	14 to 28V dc, 300mA typical (no options).
ac Supply:	Set internally to 85-100V, 95-135V ac or 190-260V.
<b>Operating Temperature</b>	0 to 55°C.
<b>Facia Sealing</b>	IP65 (Nema 4X) watertight.
<b>Dimensions</b>	144mm (5.7") wide x 72mm (2.8") high x 188mm (7.4") deep.
<b>Panel Cutout</b>	139mm (5.5") x 67mm (2.6").

## Approvals

<b>Electrical</b>	ETL (US) approved to UL508 and CSA.
<b>Interference</b>	CE Compliance.
<b>Enclosure</b>	CENELEC, FM, CSA and SAA enclosures available for hazardous areas.

## Frequency Input

<b>Range</b>	
Minimum:	0.25Hz on Rate, 0Hz on Total.
Maximum:	10KHz.
<b>Input Circuits</b>	Accepts most sine, logic and proximity switch inputs.
<b>K-factor Range</b>	0.1000 to 999,999.
<b>Non-Linear Correction</b>	Up to 10 correction points.

## 4-20mA Inputs

<b>Input Types</b>	Flow, pressure and temperature.
<b>Input Impedance</b>	250 ohms.
<b>Measurement Ranges</b>	
Pressure:	
- Steam	1kPa abs (1psia) to 100,000kPa (10,000psia).
- Condensate	1kPa abs (1psia) to 1,000kPa (145psia).
Temperature:	
- Steam	0°C (32°F) to 800°C (1472°F).
- Condensate	0°C (32°F) to 800°C (347°F).
<b>Span (Flow)</b>	999,999.
<b>Accuracy</b>	0.05%.
<b>Circuit</b>	250 ohm resistors connected to a common signal ground (current sinking).
<b>Non-Linear Correction</b>	A 20 point curve can be applied to the flow input.

## Pulse Input

<b>Type</b>	Absolute or gauge.
<b>Span</b>	Absolute or gauge pressure is programmable at 4mA and 20mA.
<b>Atmospheric</b>	If a gauge pressure sensor is used, the atmospheric pressure is programmable.

## Pulse Output

<b>Pulse Width</b>	10ms (negative going pulse).
<b>Duty Cycle</b>	49 pulses/sec max.
<b>Output</b>	An open collector transistor will sink 100mA max. (Note: Pulse output is suitable for driving remote counters or PLC's.)

## RS232/422 Option

<b>Type</b>	Both RS232 and RS422 are provided. (Note: When using the RS422, multi-point communication (RS485) can be implemented with up to 32 instruments connected to a common bus.)
<b>Function</b>	Printer and computer protocols are fully programmable.
<b>Printer</b>	A print is initiated on each reset or at a programmable time interval. (Note: Protocols are provided for roll and column printers.)
<b>Computer</b>	An ASCII based protocol enables all displayed parameters to be read and the totals to be reset.
<b>Baud rate</b>	300 to 9600.
<b>Data Bits</b>	7 or 8.
<b>Parity</b>	None, Odd or Even.
<b>Data Logging</b>	Output generated at intervals of once a minute to once every 24 hours. The totals can be programmed to reset on each print or at 24:00 hours.
<b>Time</b>	A real time clock is provided to give time and date on each output.

## 4-20mA Output Option

<b>Function</b>	The net energy is output. The 4 and 20mA points can be programmed to provide a fully scaled output.
<b>Resolution</b>	10 bits.
<b>Accuracy</b>	Better than 0.1%.
<b>Maximum Load</b>	500 ohms internally powered. 950 ohms from external 24V dc.
<b>Isolation</b>	Output is isolated.

## Relay Output Option

<b>Function</b>	High and low flow rate alarms based on the net energy.
<b>Max Switching Power</b>	250VA.
<b>Max Switching Voltage</b>	250V ac, 30V dc.
<b>Max Switching Current</b>	5 Amps.

*Important: Specifications are subject to change without notice.*

## Steam and Condensate

**Calculations** Based on 1967 IFC Formulated (ASME) equations.

**Types** Saturated and superheated steam, and water condensate.

**Temperature Range**

- Steam 0°C (32°F) to 800°C (1472°F).
- Condensate 0°C (32°F) to 175°C (347°F).

### Pressure Range

- Steam 1kPa abs (1 psia) to 100,000 kPa abs (10,000 psia).
- Condensate 1kPa abs (1 psia) to 1000 kPa abs (145 psia).

### Saturated Steam

When measuring saturated steam, it is possible to omit either the pressure or temperature sensor since, on the saturated line, there is a corresponding pressure for all temperatures.

## Dimension Drawings

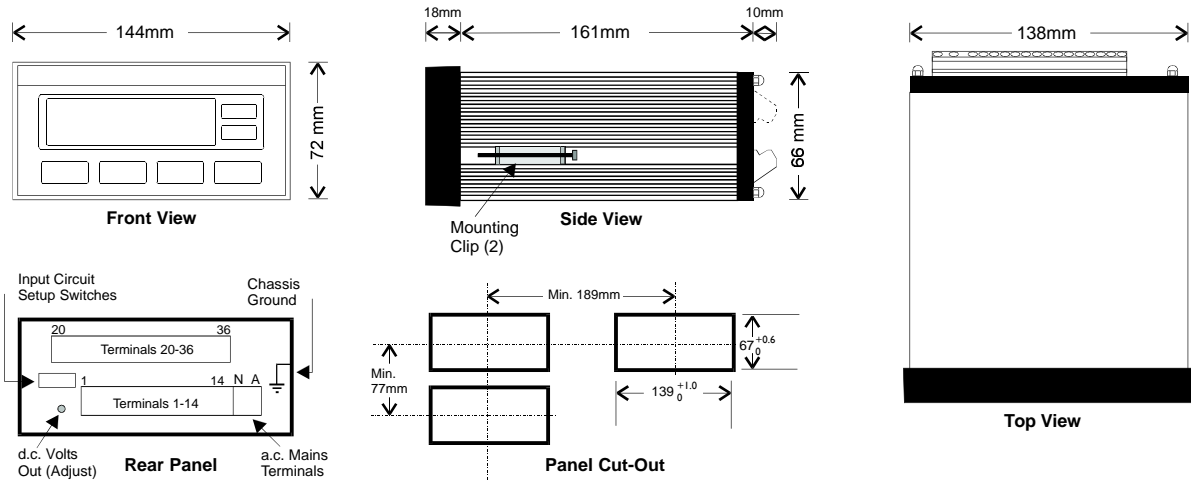

## Terminal Descriptions

Terminals Common to all Models				Isolated 4-20mA Output Option		RS232/422 Option		High & Low Relay Alarm Option	
No.		No.		No.				No.	
1	Calibration Link	9	Flow Pulse Input (+)	20	Not Used		RS232 Signal Ground	31	High - Normally Open
2	Signal Ground	10	Pulse Out	21	0 Volts		RS232 Data In	32	High - Normally Closed
3	Flow (4-20mA)	11	dc Power Out (8-24V)	22	0-10 Volts		RS232 Data Out	33	High - Common
4	Steam Temp (4-20mA)	12	dc Ground	23	-12 Volts		RS422/485 (-) Data Out	34	Low - Normally Open
5	Reset Switch	13	dc Power In	24	I (-)		RS422/485 (+) Data Out	35	Low - Normally Closed
6	Display Switch	14	Condensate Temp (4-20mA)	25	I (+)		RS422/485 (-) Data In	36	Low - Common
7	Steam Pressure (4-20mA)			26	+15 Volts		RS422/485 (+) Data In		
8	Flow Common (-)			27	Not Used		RS232 CTS		

Terminals 28, 29 & 30 on the option card are not used.

## Ordering Information

When specifying please indicate model(s) required using the following method.

415 C . 1 0 E C

<p><b>Basic Model</b></p> <p><b>Mounting</b></p> <ul style="list-style-type: none"> <li>Panel - 1</li> <li>Field - 2</li> <li>Explosionproof - 3</li> </ul>		<p><b>Special Options</b></p> <ul style="list-style-type: none"> <li>0 - No option</li> <li>C - Conformal Coating</li> <li>G - German language version</li> </ul> <p><b>Power Supply</b></p> <ul style="list-style-type: none"> <li>E - 240V ac</li> <li>A - 110V ac</li> <li>D - 14-28V dc</li> <li>J - 100V ac</li> </ul> <p><b>Standard Options</b></p> <ul style="list-style-type: none"> <li>0 - No options</li> <li>1 - Isolated 4-20mA output</li> <li>2 - RS232/422</li> <li>3 - High/Low alarms</li> <li>4 - 4-20mA and alarms</li> <li>5 - RS232/422 and alarms</li> </ul>
---	--	--



## Distributed by:

**Contrec Pty Ltd**  
 22 Hall Street Hawthorn East, Melbourne 3123 AUSTRALIA  
 Tel: +61 3 9822 8966 Fax: +61 3 9822 8329  
 Email: contrec@contrec.com.au

**Contrec - USA, LLC**  
 916 Belcher Drive Pelham AL 35124 USA  
 Tel: (205) 685 3000 Fax: (205) 685 3001  
 Email: contrec@contrec-usa.com

**Contrec Europe Limited**  
 PO Box 436 Halifax HX1 2WG, UK  
 Tel: +44 1422 254 024 Fax: +44 1422 254 025  
 Email: sales@contrec.co.uk

**Website: www.contrec.com.au**