

Heat Calculator

Model 212

Features

- Complies with OIML R75 and EN1434 standards
- Multilingual capability
- Heating, cooling and air conditioning
- Built-in density and enthalpy tables
- Meter-bus interface or RS485 communications
- Metric or US units
- 4-wire Pt100 RTD temperature inputs
- Fully programmable
- Calculates and displays Volume, Energy, Temperatures and Peak Energy
- Watertight to IP66 (Nema 4X)
- High accuracy
- CE Compliant
- 4-20mA output option



Overview

The 212 Heat Calculator is designed to measure the energy consumed in hot water heating systems and chilled water cooling systems.

The 212 is supplied complete with temperature probes and will interface with a wide range of flowmeters, including positive displacement and inferential water meters, magnetic flowmeters with pulse outputs, turbine and paddle wheel flowmeters.

Provides flexibility to meet all applications

The 212 is able to cross international boundaries in heat meter applications.

Multilingual capability, datalogging and peak/off-peak operation are standard. In addition, four modes of operation covering heating and cooling ensure that the 212 is flexible enough to meet all energy measurement applications.

The high accuracy of the 212 ensures that it meets European and International approvals for heat calculators.

Accuracy to OIML R75 Class 4 and EN1434

The 212 is supplied with two precision 4-wire Pt100 RTDs and has inbuilt correction for the non-linearity of the RTDs. For chilled water measurement where the temperature difference (Δt) is likely to be small, provision is made in the set-up program to zero out any offset between RTDs.

The 212 is fully programmable and all set-up data and totals are stored in a non-volatile memory for a minimum of 10 years.

Heat Calculator

Model 212

Watertight wall or panel mount enclosure

The 212 Heat Calculator is housed in a rugged yet attractive IP66 (Nema 4X) rated polycarbonate enclosure which is completely watertight.

Mounting is either by a wall bracket or by panel mount.

Integration with energy management systems

A Meter-bus interface enables the 212 Heat Calculator to be incorporated into energy management systems complying with European IEC 870-5 protocol standards.

The 212 is also supplied with an RS485 bus, which uses industry standard Modbus RTU protocol, for interfacing to computers and DCS systems.

Datalogging flexibility

The 212 Heat Calculator will store energy totals by hour, day, week or month for up to 31 periods. The totals are stored for each period and can be downloaded to a computer via the Meter-bus or RS485 communications ports.

Peak and off-peak registers

If selected, the peak/off-peak feature will assign two separate registers which will totalise peak energy and off-peak energy.

The changeover times between peak and off-peak are fully programmable.

4-20mA Output

A 4-20mA output option is available and can be programmed to output flow rate, energy flow rate, feed or return temperature or Δt .

Note that the high & low alarms are not available if the 4-20mA option is installed.

Modes of Operation

The 212 Heat Calculator is flexible enough to handle a wide range of applications. Four operating modes are available.

- **Heating Mode** where positive Δt 's only are totalised.
- **Cooling Mode** where negative Δt 's only are totalised.
- **Heating/Cooling Mode** where the flow of energy may be for heating or cooling. In this mode the energy total is increased regardless of whether Δt is positive or negative.
- **Charge/Discharge Mode** where two separate registers totalise positive and negative totals.

Calculates the density and enthalpy of water

The 212 Heat Calculator measures the temperature in the feed and return lines and, from this, calculates the density and enthalpy of the water.

By also measuring the volume of water flowing in the system, the 212 will then compute the energy consumed.

Power is calculated as:

$$P = V \times \rho \times (h_{TV} - h_{TR})$$

where **P** = Power (W)

V = Volumetric flow rate (m³/s)

ρ = Density (kg/m³)

h_{TV} = Specific enthalpy (J/kg) at Feed temperature

h_{TR} = Specific enthalpy (J/kg) at Return temperature

The volume, energy, temperatures and peak energy are all calculated and can be displayed on the large LCD.

General

Display

Type: 7 digit LCD - 7 numeric digits and 11 alpha characters.
 Digits: 15.5mm (0.6") high.
 Characters: 6mm (0.24") high.
 Display Units: kWh, MWh, MJ, GJ, therm, BTU x 1000, tons x hours (refrigeration).

Maximum Thermal Power
 3000MW.

Measurement Time
 0.5s.

Accuracy OIML R75 Class 4 and EN1434.

Approvals Approved by Swiss Federal Office of Metrology to OIML Class 4.

Interference CE Compliance.

Power Requirements

dc Power: 12 to 24V dc @ 100mA maximum.
 ac Power: Supplied via power adaptor.

Physical

Temperature

Operating: 5 to 55°C.
 Storage: -20 to 70°C.

Environmental Class

EN1434 Classes A & C.

Enclosure

Protection: IP66 (Nema 4X) watertight.
 Materials: Polycarbonate and ABS.

Mounting Options

Wall: Wall mount bracket.
 Panel: Mounting clips.

Inputs

Flowmeter

Type: Frequency or pulse between 0.01Hz to 20KHz. Default low frequency cutoff is 0.25Hz.

K-factor Range: Programmable in the range 0.001 to 999,999.9 pulses per litre, m³, US gallon or ft³.

Signal Type: Pulse, open collector, reed switch, proximity switch or coil.

Location: In either the return or feed lines.

Temperature

Type: 4-wire Pt100 RTD's to IEC 751. 1/10 DIN.
 Location: 1 x Feed Line and 1 x Return Line.
 Linearisation: Built-in RTD linearisation.
 Temp Range: -10 to 220°C (1 to 200°C approved).
 Temp Difference: 1 to 200K (3 to 199K approved).
 Measurement Time: 3s.
 Cable Length: < 50m.
 Connection: G½ B.

Outputs

Pulse

Type: Open collector will sink up to 100mA, 30V dc maximum.

Width: 10ms.

Function: Volume or Energy (scaled).

Frequency: 1 pulse every preset number of units of energy or volume total.

Alarm (Not available with 4-20mA output)

Type: Two solid state opto-isolated relays which will sink up to 100mA, 30V dc maximum.
 Function: High and low alarms individually programmable as unsigned values for flow rate, energy flow rate, feed temperature, return temperature or temperature difference.

4-20mA Output Option

Function: Volumetric flow rate, energy flow rate, feed or return temperature, Δt.

Accuracy: 0.1%.

Span: Programmable.

Load: Maximum of 300 ohms at 12V.

Meter-Bus

Type: Conforms to CEN/TC176 Meter-bus standard.
 Protocol: IEC 870-5.

RS485

Data Transmitted: All data calculated can be transmitted.

Baud Rate: 300 to 9600 baud.

Parity: Odd, even or none.

Stop Bits: One or two.

Bus Address: Programmable for multiple instruments on the same bus.

Protocol: Modbus RTU.

Important: Specifications are subject to change without notice.

Dimension Drawings

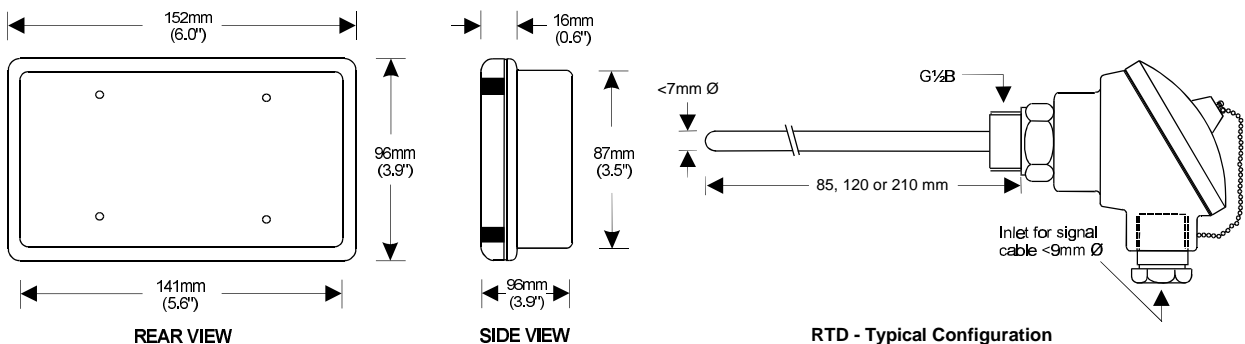

Terminal Descriptions

RTD Connections		Flowmeter Signals		Communications		Alarm Relays		Power Supply	
No.		No.		No.		No.		No.	
1	High temp RTD Current (+)	9	Namur Switch (+)	24	Meter-Bus	52	Relay 0 (+) dc voltage only	50	12V dc Supply (+)
2	High temp RTD Current (-)	10	Flow Signal Input	25	Meter-Bus	53	Relay 0 (-) dc voltage only	51	12V dc Supply (-)
3	Low temp RTD Current (+)	11	Coil Reference			54	Relay 1 (+) dc voltage only		
4	Low temp RTD Current (-)	12	Flow Signal Common	56	RS485 (+)	55	Relay 1 (-) dc voltage only	58	Shields
5	High temp RTD Input (+)			57	RS485 (-)	4-20mA Output			
6	High temp RTD Input (-)								
7	High temp RTD Input (+)	16	Pulse Output (+)			No.			
8	High temp RTD Input (-)	17	Pulse Output (-)			52	4-20mA (+)		
						53	4-20mA (-)		

Ordering Information

When specifying please indicate model(s) required using the following method.

212 . 2 0 E 1 S

<p>Basic Model</p> <p>Type of Mounting Panel Mount - 1 Wall Mount - 2</p> <p>Options No options - 0 4-20mA Out - 1</p>		<p>OIML R75 Compliant</p> <p>Temperature Sensor 0 - None 8 - 85mm Insertion 1 - 120mm Insertion 2 - 210mm Insertion</p> <p>Type of Power N - 12V dc Power E - European Adaptor (220V ac) U - UK Adaptor (220V ac) A - USA Adaptor (110V ac) H - Australian Adaptor (240V ac)</p>
---	--	--

contrec

Distributed by:

Contrec Pty Ltd
 22 Hall Street Hawthorn East, Melbourne 3123 AUSTRALIA
 Tel: +61 3 9822 8966 Fax: +61 3 9822 8329
 Email: contrec@contrec.com.au

Contrec - USA, LLC
 916 Belcher Drive Pelham AL 35124 USA
 Tel: (205) 685 3000 Fax: (205) 685 3001
 Email: contrec@contrec-usa.com

Contrec Europe Limited
 PO Box 436 Halifax HX1 2WG, UK
 Tel: +44 1422 254 024 Fax: +44 1422 254 025
 Email: sales@contrec.co.uk

Website: www.contrec.com.au